

process measurement solutions



The level solutions catalogue



Precision...

level measurement & control...

Powerful FMCW technology

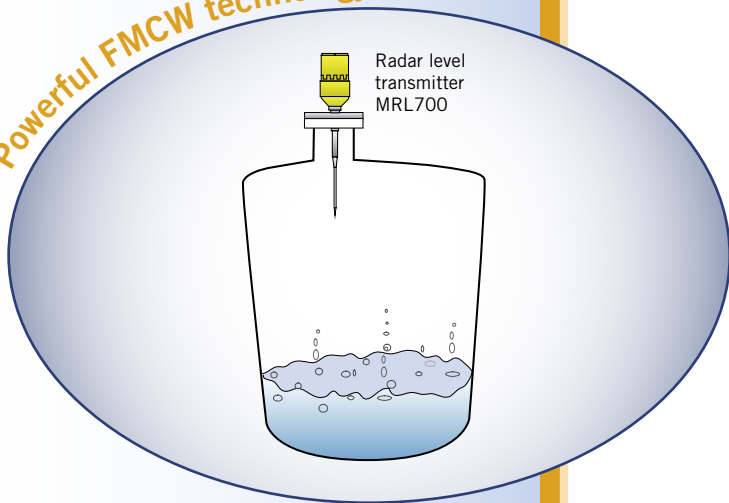

Radar level transmitters

Solartron Mobrey's competitively priced Radar transmitters use FMCW (Frequency Modulated Continuous Wave) technology to give premium performance. Options include the unique process seal antenna for total vessel integrity

Economic non-contact solutions

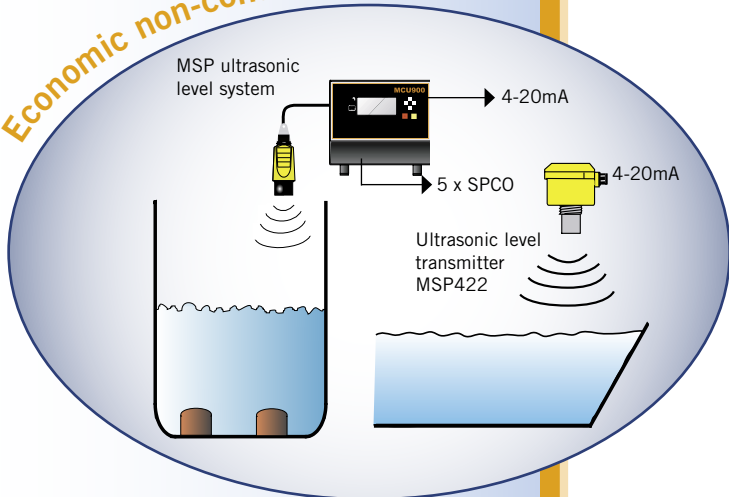

Ultrasonic level transmitters and systems

Ultrasonic level transmitters and control systems for applications where reliability and repeatability are required at the most economic price. Duties include inventory control, process vessel level and wetwell/sump control.

Tough solutions for tough applications

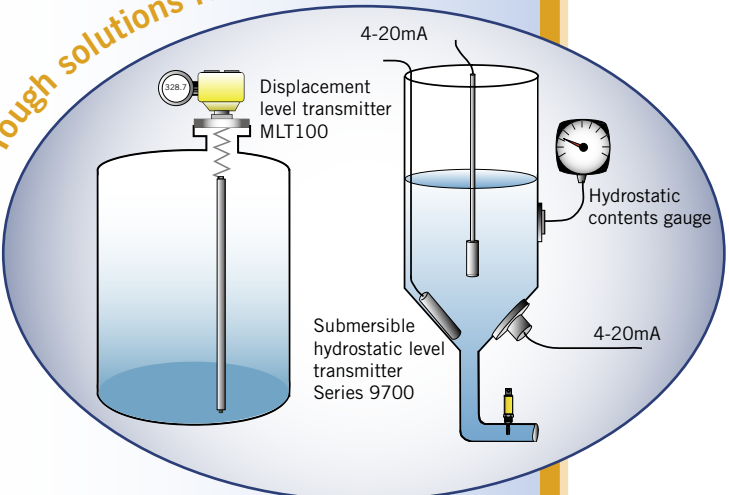

Displacer level transmitters

One of the most advanced displacer based devices on the market, coupling the time proven buoyancy principle with state of the art electronics in an instrument of high reliability and stability to measure level, contents or interface. Mounting may be either directly into a vessel or externally mounted in a chamber. Solartron Mobrey displacer transmitters will operate in many difficult level measurement applications from condensate drums to knock-out pots.

Hydrostatic level transmitters

Tank contents transmitters and accessories designed to perform in the arduous conditions of today's industrial measurement applications. They provide the measurement solution where in-tank problems such as foaming, vapour layers and temperature gradients prohibit the use of other instrumentation.

...with products that perform



Radar level transmitters MRL700

- ▶ 316 Stainless steel wetside with PTFE rod antenna
- ▶ 1" Threaded mounting
- ▶ HART digital communications
- ▶ Certified for use in Zone O hazardous areas
- ▶ Horn antenna option for difficult applications
- ▶ Process seal antenna for non-invasive installation
- ▶ Measuring range up to 35m
- ▶ Operating temperature from -40°C to + 400°C
- ▶ Operating pressure full vac to 40b
- ▶ Reference accuracy +/- 3mm
- ▶ Resolution +/- 3mm



Hydrostatic level transmitters Series 9700

- ▶ Flush mount ceramic sensor in tough 316SS body
- ▶ 2 Wire 24V dc loop powered
- ▶ 4-20mA output proportional to level and contents
- ▶ Option of remote non-interactive zero and span
- ▶ Ideal for industrial or marine applications
- ▶ Wide range of mounting options
- ▶ Low cost installation
- ▶ Range to 100m H₂O
- ▶ Certified for use in zone O hazardous areas
- ▶ Submersible models
- ▶ Flanged or threaded connections
- ▶ 3A approved models for hygienic applications
- ▶ Self powered versions



Ultrasonic level transmitters and systems MSP400 and MSP900

- ▶ 2 Wire 24V dc loop powered transmitter with 8m range
- ▶ Reference accuracy +/- 3mm
- ▶ Resolution +/- 1.6mm
- ▶ Measuring range up to 11m with ultrasonic systems
- ▶ Contents measurement displayed may be in any units, easily programmed by the customer.
- ▶ 4-20mA output
- ▶ Control systems with 5 relay outputs:
Relays and current are field programmable
- ▶ Certified for use in zone O hazardous areas
- ▶ Open channel flow measurement capability
- ▶ Differential level for screens/filters
- ▶ HART digital comms



Displacer level transmitter MLT100

- ▶ Level, contents or interface duty
- ▶ 2 Wire 24V dc loop powered
- ▶ 4-20mA output
- ▶ HART digital communications
- ▶ Hazardous area certification
- ▶ Fast and simple calibration in tank or on bench
- ▶ Non-interactive zero and span
- ▶ Direct or external chamber mounting
- ▶ Optional local indicator
- ▶ Range to 3m (longer on request)
- ▶ Pressure and temperature to 200 bar and 300°C



Liquid level switches for

These economical and reliable switches are ideal for small tank or pipe mounting. Particularly well suited to general industry and OEM markets

A range of robust, reliable level switches for high and low alarm. Choose from traditional float switches, either side or top mounted, or vibrating fork switches

Small and lightweight

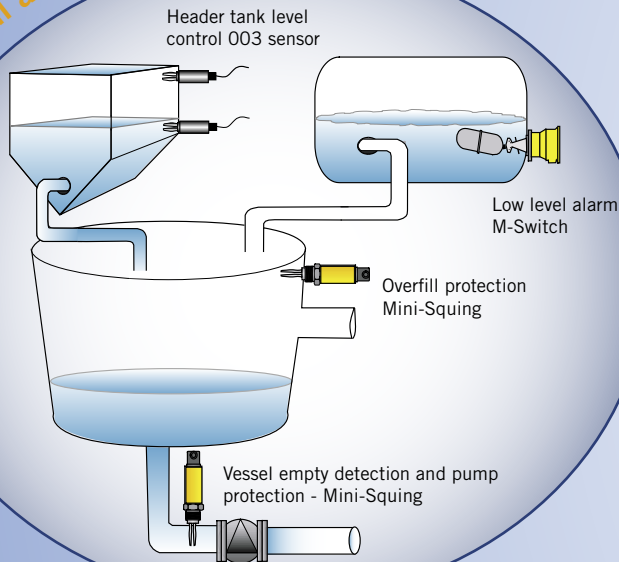

Rugged construction for tough process duties

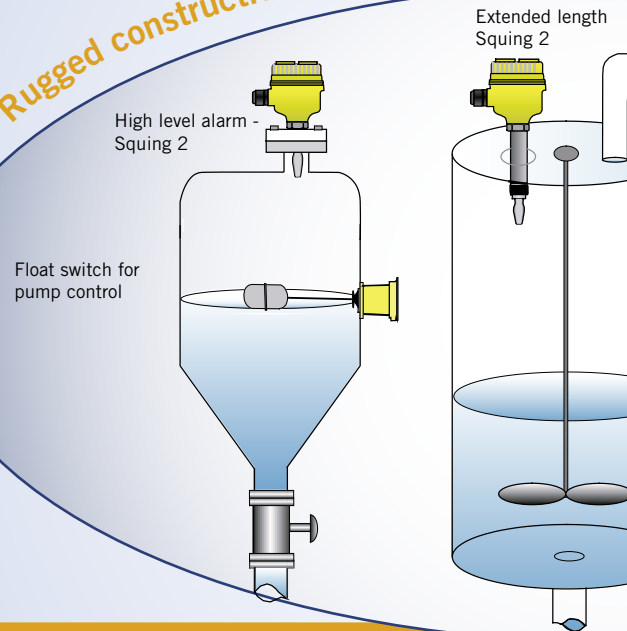

Ultrasonic gap switch 003

- ▶ One piece moulded PPS body
- ▶ 24V dc powered with relay or solid state output from encapsulated electronics
- ▶ 1" or 3/4" BSPT threaded mounting
- ▶ Pressure and temperature to 20b and 105°C
- ▶ Factory fitted with 3m connecting cable



Vibrating fork switch - Mini-Squing

- ▶ Stainless steel wetside and body
- ▶ 24-264V dc or ac powered with solid state output
- ▶ 1" or 3/4" BSPT threaded mounting
- ▶ Pressure and temperature to 100b and 150°C
- ▶ 3A Approved models with hygienic connections

Float level switch - M-Switch

- ▶ Stainless steel wetside and body
- ▶ Glandless construction
- ▶ Snap-action switching rated 15A
- ▶ 2" BSPT threaded mounting
- ▶ Pressure and temperature to 50b and 130°C
- ▶ Explosion proof options EExd



Vibrating fork level switch - Squing 2

- ▶ Threaded or flange mounting
- ▶ 3A Approved models with hygienic connections
- ▶ Extended length to 3m available
- ▶ Stainless steel wetside with ECTFE/PFA coating option for corrosive applications
- ▶ 24-264V dc or ac powered with relay or solid state output
- ▶ Intrinsically safe option EEx ia
- ▶ Explosion proof options EEx d



Horizontal 2 magnet float switch

- ▶ Simple, rugged and reliable
- ▶ Side or top mounting
- ▶ Direct or chamber mounting
- ▶ Electrical or pneumatic switching
- ▶ Weatherproof to IP66
- ▶ Submersible IP68 models available
- ▶ Materials of construction to suit most liquids
- ▶ Hazardous area models eeX D and EEx ia
- ▶ Marine approvals



alarm and pump control

in duties or pump control applications. Including, ultrasonic switch systems or

A wide range of standard or custom designed ultrasonic sensors and remote control electronics for use with a variety of liquids in all applications. Failsafe high or failsafe low systems available.

ies

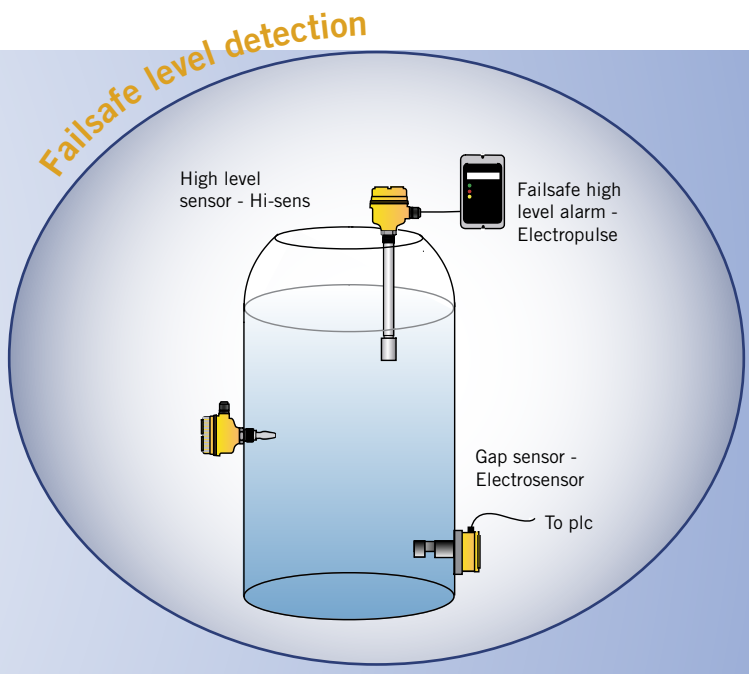
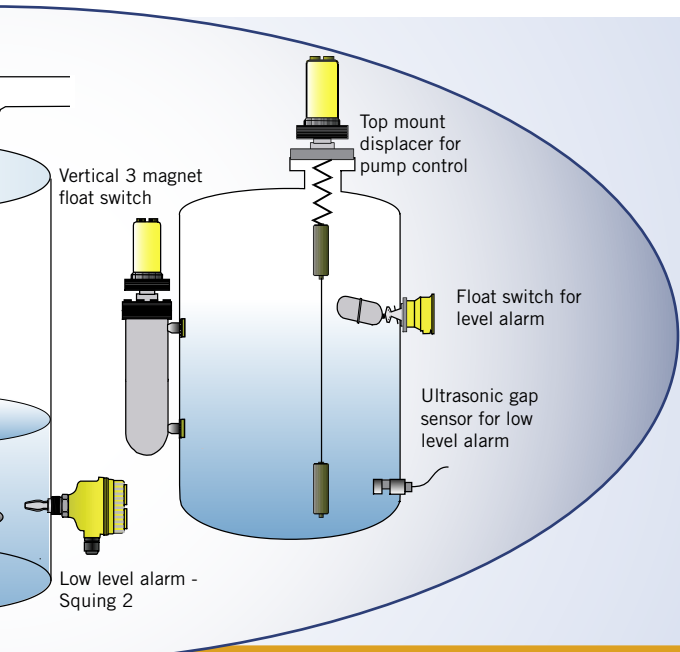

Vertical 3 magnet float and displacer switch

- Direct or external cage mounting
- Up to 4 switch points
- Wide standard range or custom design up to ANSI #2500 rating
- Unique 3 magnet latching switches with no springs

Ultrasonic level switch system

- No moving parts
- Wide range of materials of construction to suit most applications
- Extensive custom design expertise
- Sensors to suit most liquids and applications:
 - Clean liquids
 - Dirty liquids
 - Corrosive liquids
 - Cryogenic liquids
 - Interface detection
 - Pressure to 280b
 - Temperature to 250°C



Mobrey failsafe ultrasonic level switch systems comprise a liquid level sensor and control electronics:

Ultrasonic sensors

- Select a sensor to suit the liquid and process conditions:
 - Gap sensor for low level
 - Unique patented Hi-Sens for high level



Control electronics

- Select the style of electronics required:
 - Electrosensor to allow interface to standard plant control system (8/16mA switching)
 - Electropulse for ultimate fail safety in critical applications



Level measurement for the water industry

Solartron Mobrey offers a comprehensive range of instrumentation to satisfy the needs of both the potable and waste water industries. This extensive portfolio includes suspended solids monitoring, ultrasonic sludge blanket level, control and pressure transmitters and open channel flow monitoring equipment

Sludge level control

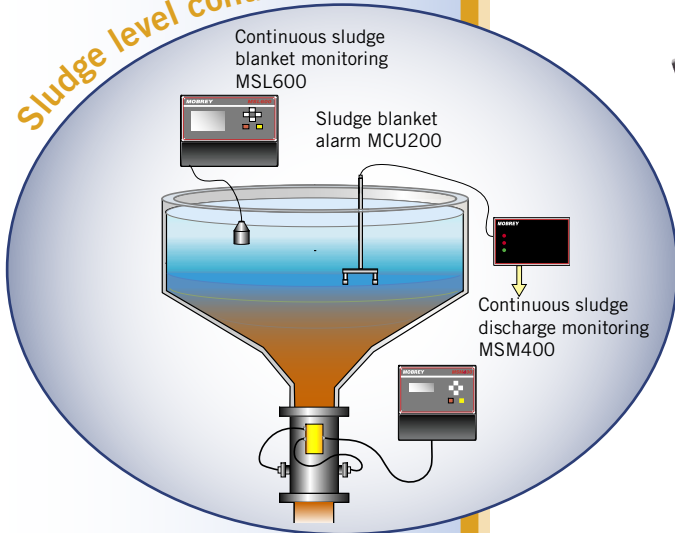

Suspended solids monitoring & control

With over 30 years experience Solartron Mobrey is a recognised leader in the field of ultrasonic suspended solids detection and control.

- Our feature rich instruments offer
- ▶ Built-in display, control and alarm options
 - ▶ Simple menu driven programming
 - ▶ Local programming via a membrane key pad
 - ▶ Continuous sludge blanket monitoring
 - ▶ Fully configurable output functions
 - ▶ Accuracy +/- 1db
 - ▶ IP65 wall mounting enclosures
 - ▶ 4-20mA output options

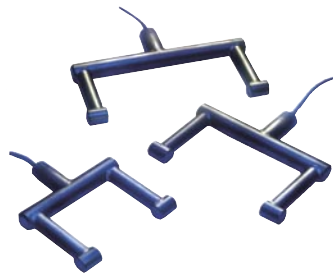

Open channel flow level measurement and control

Solartron Mobrey's expertise in ultrasonics and pressure has produced a new generation of level measurement instrumentation specifically designed to cater for the requirements of the water industry.

Solartron Mobrey is a renowned authority in the use of level instrumentation for open channel flow applications.

Open channel flow

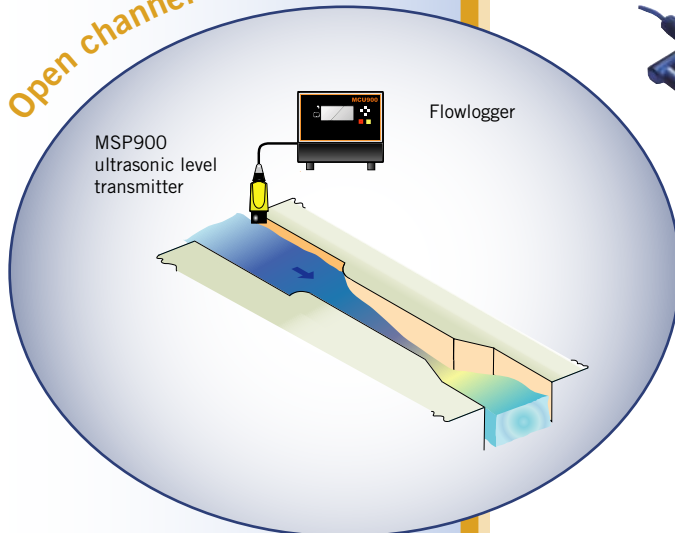

- ▶ Customised user profiles for complex tank shapes and flow structures
- ▶ Internal or external temperature compensation
- ▶ Process variable displayed in any engineering units
- ▶ 4-20mA output
- ▶ 5 Relays for wetwell pump control
- ▶ IP65 enclosure
- ▶ RS232 Comms options available
- ▶ Wall, rack and panel mounting
- ▶ Flow measurement in accordance with BS3680 Part 4

Steam boiler level control...

...fit and forget

From float level controls and electrode probes through to high integrity electronic gauging systems, Solartron Mobrey offers the complete package for steam boiler level control

Hydrastep electronic gauging system

The Solartron Mobrey Hydrastep electronic gauging system is the ideal fit and forget solution for monitoring drum water level in steam generating plant. Failure to detect low water levels in steam raising plant can have costly and potentially disastrous consequences. Reliable water level detection is vital to prevent damage to plant and personnel. Designed for totally reliable operation, Hydrastep is both fail-safe and fault tolerant.

- ▶ Continuous fail-safe monitoring
- ▶ Fault indication on all displays
- ▶ Zero maintenance
- ▶ Local & remote displays
- ▶ Exceptional reliability
- ▶ Approved by insurance companies
- ▶ No missed incidents

Hydratect steam/water detection system

Hydratect is for use wherever the detection of water or steam is vital for safe and efficient operation

Mobrey and Erab level controls

Float level controls and electrode probe controls covering both point and continuous level applications. The range also includes high integrity self-monitoring equipment to comply with the most onerous boiler house requirements, giving a full range of control and alarm applications on steam boilers.

- ▶ Compact robust designs
- ▶ Self-monitoring, high integrity
- ▶ Suitable for pressures up to 62b saturated steam
- ▶ Smart, no start if wiring is incorrect
- ▶ No head mounted electronics
- ▶ May be grouped in various configurations to suit application
- ▶ Marine approvals

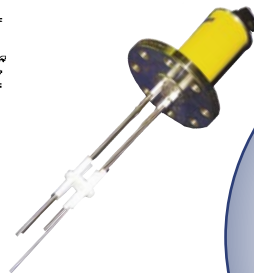

Boiler water level monitoring

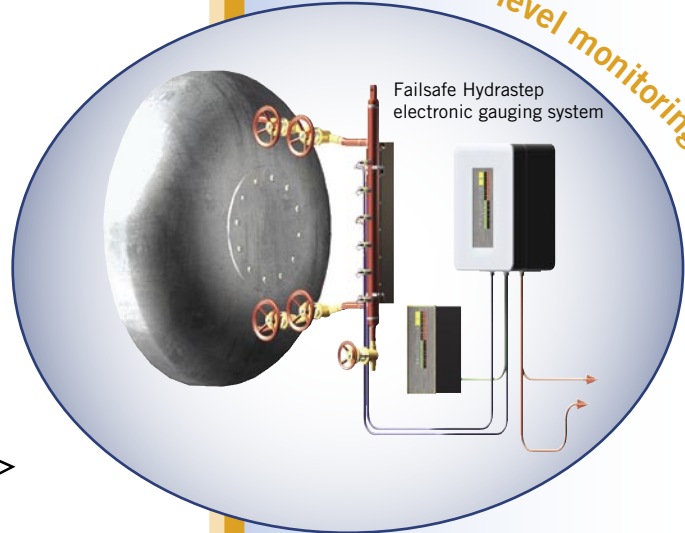

Boiler level control

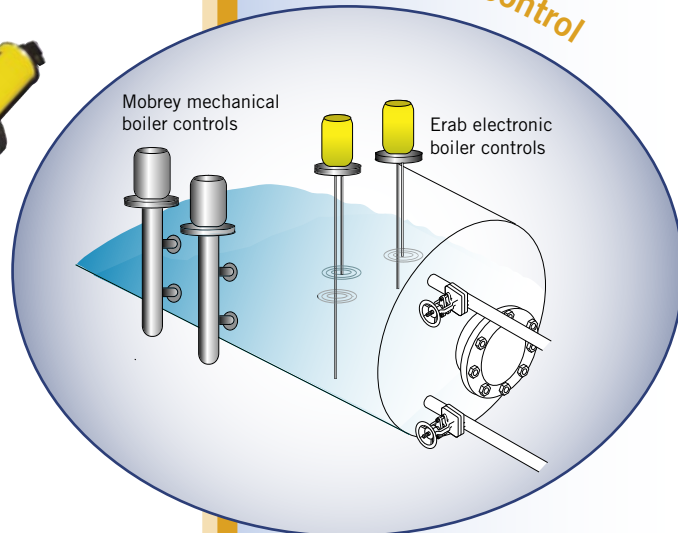

Solartron Mobrey is a dynamic company supplying precision measurement solutions to the process and oil and gas industries. Products in the range include:

Density

Industrial densitometers built to tackle the most difficult and demanding process and metering applications. Rugged and reliable with very low maintenance, they are the industry standard for on-line density measurement.

Viscosity

Process viscosity transmitters and analysers, including complete analyser systems. Solartron Mobrey's products are replacing many existing technologies and are used in applications where previously only laboratory measurements could be made.

Flow measurement

Flow measurement capability covering everything from orifice plates, flow metering for closed pipes, open channels and partially full pipes to wet gas and multiphase flow measurement in offshore subsea applications and unmanned metering skids.

Temperature measurement

A wide range of intrusive temperature elements from thermocouples and thermowells to complete assemblies and temperature transmitters

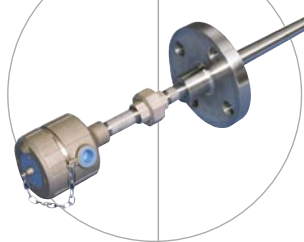
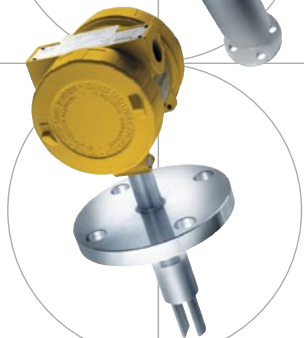

Solartron Mobrey Limited

158 Edinburgh Avenue Slough Berks UK SL1 4UE
Tel: +44 (0)1753 756600 Fax: +44 (0)1753 823589
e-mail: enquiries@solartron.com www.solartronmobrey.com

Solartron Mobrey GmbH	Deutschland	tel: 0211/99 808-0
Solartron Mobrey Ltd	China	tel: 021 6353 5652
Solartron Mobrey sp z o o	Polska	tel: 022 871 7865
Solartron Mobrey AB	Sverige	tel: 08-725 01 00
Solartron Mobrey SA	France	tel: 01.30.17.40.80
Solartron Mobrey SA-NV	Belgium	tel: 02/465 3879
Solartron Mobrey	USA	tel: (281) 398 7890



a Roxboro Group Company



The right is reserved to amend details given in this publication without notice